

DETAIL B

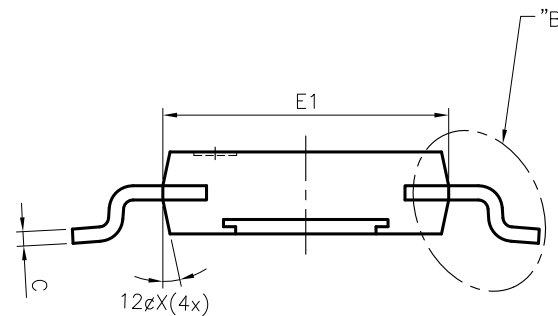
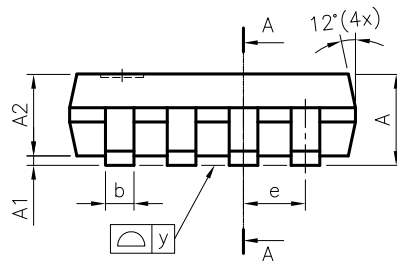

SECTION A-A

NOTE :

1. CONTROLLING DIMENSION : mm
2. LEAD FRAME MATERIAL : OLIN C7025
3. DIMENSION "D" DOES NOT INCLUDE MOLD FLASH, TIE BAR BURRS AND GATE BURRS. MOLD FLASH, TIE BAR BURRS AND GATE BURRS SHALL NOT EXCEED 0.006"[0.15mm] PER END DIMENSION "E1" DOES NOT INCLUDE INTERLEAD FLASH. INTERLEAD FLASH SHALL NOT EXCEED 0.010"[0.25mm] PER SIDE.
4. DIMENSION "b" DOES NOT INCLUDE DAMBAR PROTRUSION. ALLOWABLE DAMBAR PROTRUSION SHALL BE 0.003"[0.08mm] TOTAL IN EXCESS OF THE "b" DIMENSION AT MAXIMUM MATERIAL CONDITION. DAMBAR CANNOT BE LOCATED ON THE LOWER RADIUS OR THE FOOT. MINIMUM SPACE BETWEEN PROTRUSION AND AN ADJACENT LEAD TO BE 0.0028"[0.07mm]
5. TOLERANCE : ±0.010"[0.25mm] UNLESS OTHERWISE SPECIFIED.
6. OTHERWISE DIMENSION FOLLOW ACCEPTABLE SPEC.

OPTION	PAD SIZE	EXPOSED PAD DIMENSION (mm)					
		E2		D1			
		MIN	NOM	MAX	MIN	NOM	MAX
A.)1.7272x1.788mm		1.2192	---	---	1.280	---	---
B.)1.7272x2.30mm		1.2192	---	---	1.292	---	---

SYMBOLS	DIMENSIONS IN MILLIMETERS		
	MIN.	NOM.	MAX.
A	---	---	1.10
A1	0.05	---	0.15
A2	0.76	0.86	0.95
b	0.22	0.30	0.38
c	0.08	0.15	0.23
D	2.90	3.00	3.10
E	4.80	4.90	5.00
E1	2.90	3.00	3.10
e	---	0.65	---
L	0.40	0.53	0.66
y	0.00	---	0.076
θ	0°	3°	6°

CUSTOMER :		<b>LINGSEN</b> 5-1 NAN 2ND ROAD T.E.P.Z PRECISION IND., LTD TAICHUNG, TAIWAN R. O. C	
APPROVED BY	DATE	TITLE:	
DRAW BY: <i>Jasmin Liu</i>	04/27/15	8L MSOP PACKAGE OUTLINE DRAWING FOR EXPOSED PAD STRUCTURE	
CHECK BY: <i>Andersen Chang</i>	04/28/15	DWG. NO.	REV. 3
APPROVAL: <i>Terence Lin</i>	04/30/15	PO-MSOP-010	
APPROVAL: <i>Andy Yang</i>	04/30/15	UNIT : mm	SCALE : 18/1 SHEET 1 OF 1